

# Sierra II Pioneer Stretch T-24 Concrete Restroom - (16'-8" x 18'-0")

NTS - PRELIMINARY NOT FOR CONSTRUCTION

### STANDARD ITEMS IN SIERRA CONCRETE BUILDING PACKAGE:

**WALLS:** 8" DRY-STACK CMU, (concrete filled & steel reinforced). BROWN OR GRAY COLOR, SPLIT OR SMOOTH EXTERIOR FINISH.  
**PREFAB ROOF PANELS:** STRUCTURAL INSULATED PANELS. INTERIOR & EXTERIOR SHEATHING IS 7/16" STRUCTURAL OSB, R-23.  
**ROOFING:** HI-RIB METAL ROOFING & TRIM OVER ROOFING FELT, MOCHA (dark brown) COLOR, OPTIONAL ROOFING COLORS AVAILABLE.  
**INTERIOR FINISH:** WHITE FRP ON WALLS & VAULTED CEILING, UNFINISHED INTERIOR MECHANICAL ROOM WALLS.  
**DOORS & FRAMES:** 3'-0" x 7'-0" GALV. STEEL DOOR, HONEYCOMB CORE, 2" FRAME, POWDERCOATED BLACK; COMMERCIAL HARDWARE.  
**WINDOWS:** TRANSLUCENT LEXAN IN STEEL FRAME, POWDERCOATED BLACK.  
**SKYLIGHTS:** RECTANGULAR IN ANODIZED ALUMINUM FRAME. STD. IN SIERRA III & IV, OPTIONAL IN SIERRA & PIONEER I, II & STRETCH.  
**WALL VENTS:** EXPANDED STEEL MESH OVER GALV. LOUVERS W/ INSECT SCREEN IN STEEL FRAME, POWDERCOATED BLACK.  
**AVAILABLE FIXTURE PACKAGES:**  
**PLUMBING:** CHINA OR STAINLESS STEEL FIXTURES, GRAB BARS, MIRRORS; STALL PARTITIONS & DOORS; SHOWER FIXTURES.  
**ELECTRICAL:** INTERIOR & EXTERIOR LIGHTS, PHOTOEYE, MAIN BREAKER PANEL.  
**OPTIONS (must be on quote to be supplied):**  
 SIGNS, PAPER & SOAP DISPENSERS, WASTE RECEPTACLES, DIAPER CHANGING STATIONS, LAV SHIELDS (lavatory pipe insulation boots), COMFORT HEAT, HAND DRYERS, WATER HEATER PKG., DOOR CLOSERS, ELECT. DOOR LOCKS, CONCESSION COUNTER & ROLL-UP WINDOW, ROOF EXTENSION, 3-TAB COMPOSITION OR CEDAR ROOFING, CUSTOM EXTERIORS (wood, stucco, fiber-cement, masonry).  
**IMPORTANT: REFER TO QUOTE AND SPEC. FOR THE ITEMS INCLUDED WITH YOUR BUILDING PACKAGE.**

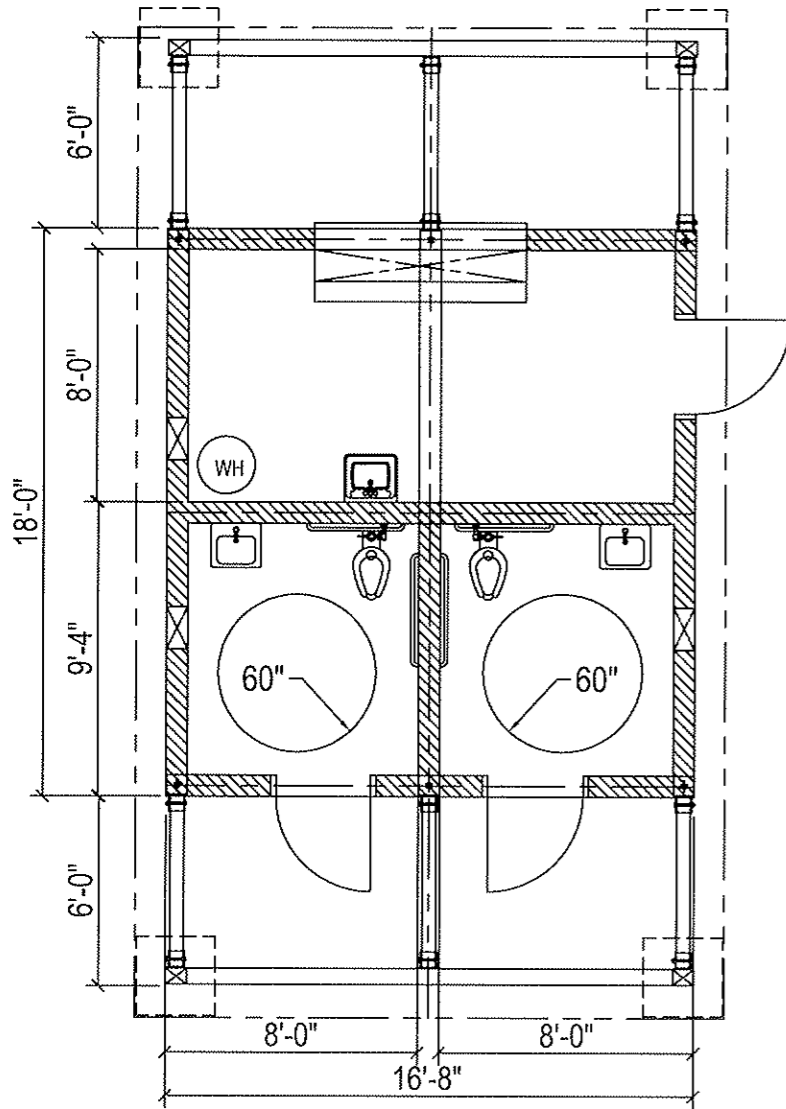

FLOOR PLAN

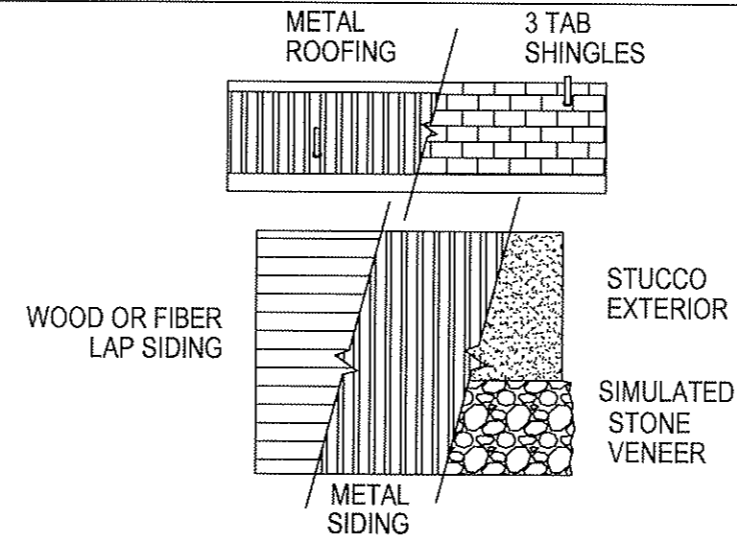

ROOFING CHOICES AND OPTIONAL EXTERIORS

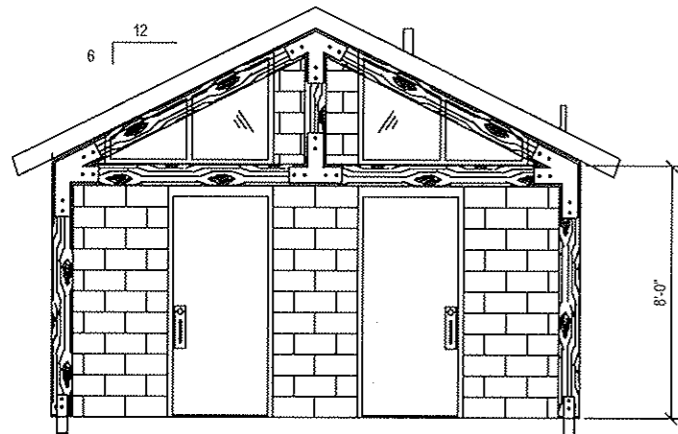

FRONT VIEW

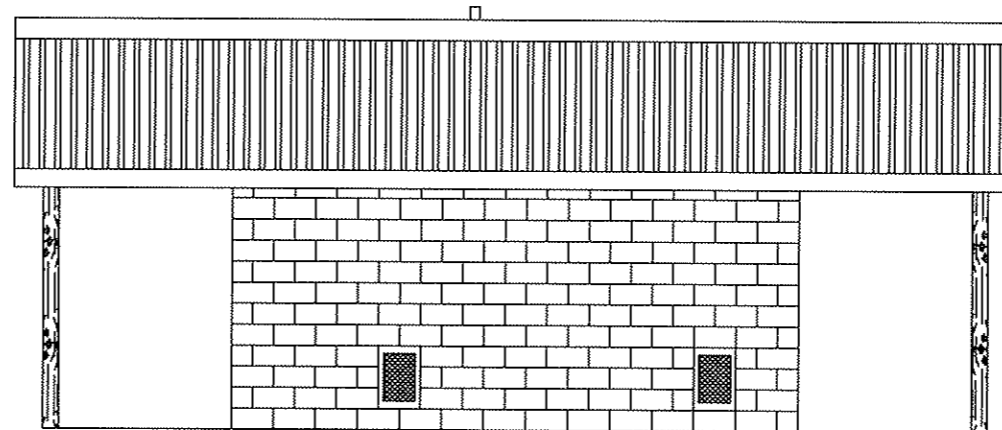

SIDE ELEVATION

**ROMTEC**  
 18240 NORTH BANK ROAD - ROSEBURG, OR 97470  
 (541)-496-3641 info@romtec.com  
 www.romtec.com

MODEL:  
**2034**

DATE  
 MM/DD/YY

REVISIONS

DATE	BY

DRAWN BY:  
 BE

SHEET NO.

**A2.1**