

# Sierra II Pioneer T-24 Concrete Restroom - (16'-8" x 9'-4")

NTS - PRELIMINARY NOT FOR CONSTRUCTION

### STANDARD ITEMS IN SIERRA CONCRETE BUILDING PACKAGE:

**WALLS:** 8" DRY-STACK CMU, (concrete filled & steel reinforced). BROWN OR GRAY COLOR, SPLIT OR SMOOTH EXTERIOR FINISH.

**PREFAB ROOF PANELS:** STRUCTURAL INSULATED PANELS. INTERIOR & EXTERIOR SHEATHING IS 3/16" STRUCTURAL OSB. R-23.

**ROOFING:** HI-RIB METAL ROOFING & TRIM OVER ROOFING FELT, MOCHA (dark brown) COLOR, OPTIONAL ROOFING COLORS AVAILABLE.

**INTERIOR FINISH:** WHITE FRP ON WALLS & VAULTED CEILING, UNFINISHED INTERIOR MECHANICAL ROOM WALLS.

**DOORS & FRAMES:** 3'-0" x 7'-0" GALV. STEEL DOOR, HONEYCOMB CORE, 2" FRAME, POWDERCOATED BLACK; COMMERCIAL HARDWARE.

**WINDOWS:** TRANSLUCENT LEXAN IN STEEL FRAME, POWDERCOATED BLACK.

**SKYLIGHTS:** RECTANGULAR IN ANODIZED ALUMINUM FRAME. STD. IN SIERRA III & IV, OPTIONAL IN SIERRA & PIONEER I, II & STRETCH.

**WALL VENTS:** EXPANDED STEEL MESH OVER GALV. LOUVERS W/ INSECT SCREEN IN STEEL FRAME, POWDERCOATED BLACK.

### AVAILABLE FIXTURE PACKAGES:

**PLUMBING:** CHINA OR STAINLESS STEEL FIXTURES, GRAB BARS, MIRRORS; STALL PARTITIONS & DOORS; SHOWER FIXTURES.

**ELECTRICAL:** INTERIOR & EXTERIOR LIGHTS, PHOTOEYE, MAIN BREAKER PANEL.

### OPTIONS (must be on quote to be supplied):

SIGNS, PAPER & SOAP DISPENSERS, WASTE RECEPTACLES, DIAPER CHANGING STATIONS, LAV SHIELDS (lavatory pipe insulation boots),

COMFORT HEAT, HAND DRYERS, WATER HEATER PKG., DOOR CLOSERS, ELECT. DOOR LOCKS, CONCESSION COUNTER & ROLL-UP

WINDOW, ROOF EXTENSION, 3-TAB COMPOSITION OR CEDAR ROOFING, CUSTOM EXTERIORS (wood, stucco, fiber-cement, masonry).

**IMPORTANT: REFER TO QUOTE AND SPEC. FOR THE ITEMS INCLUDED WITH YOUR BUILDING PACKAGE.**

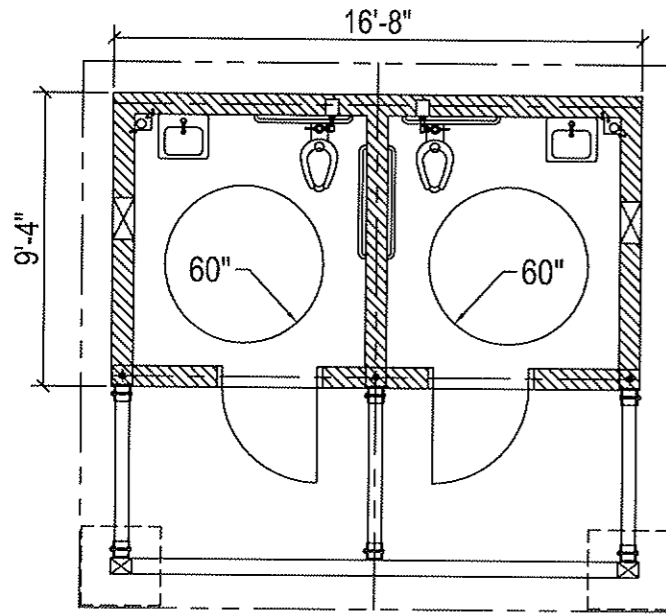

FLOOR PLAN

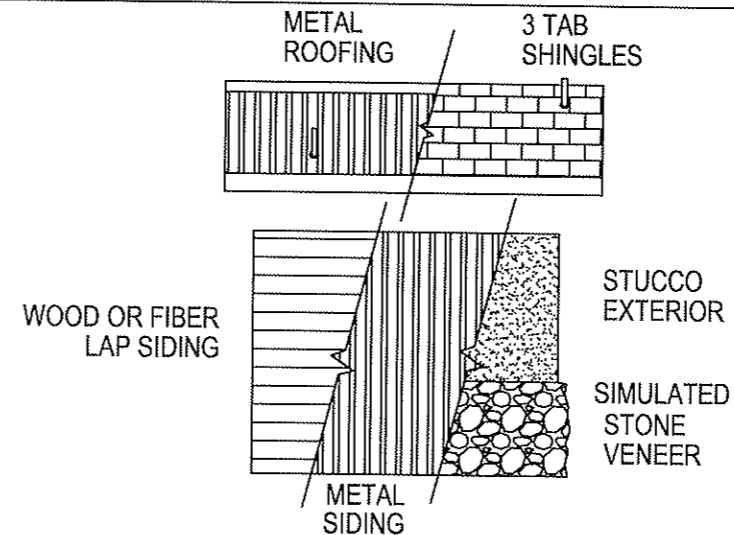

ROOFING CHOICES AND OPTIONAL EXTERIORS

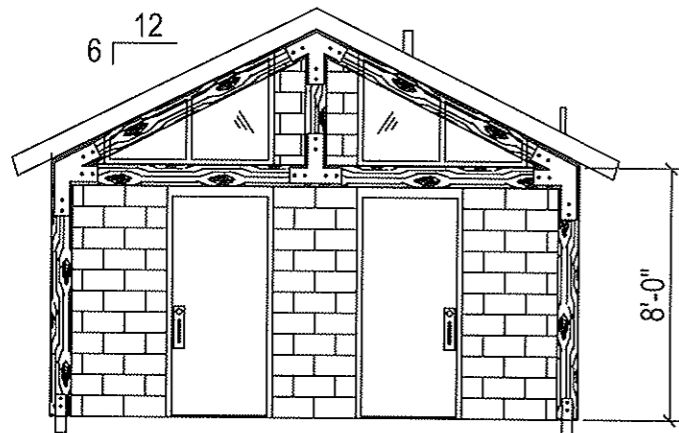

FRONT VIEW

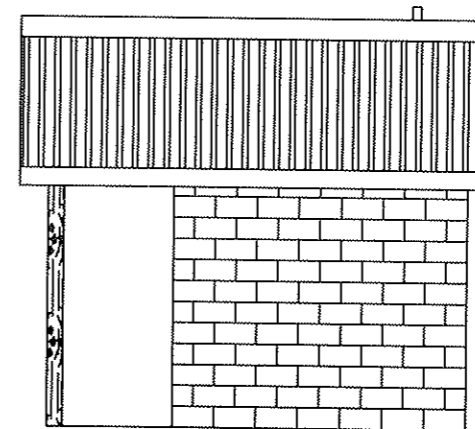

SIDE ELEVATIONS

**ROMTEC**  
18240 NORTH BANK ROAD - ROSEBURG, OR 97470  
(541)-496-3541 info@romtec.com  
www.romtec.com

MODEL:

2018

DATE

MM/DD/YY

REVISIONS

DATE

BY

DRAWN BY:

BE

SHEET NO.

A2.1